



Cambridge IGCSE™

CANDIDATE
NAME

CENTRE
NUMBER

| | | | | |
|--|--|--|--|--|
| | | | | |
|--|--|--|--|--|

CANDIDATE
NUMBER

| | | | |
|--|--|--|--|
| | | | |
|--|--|--|--|

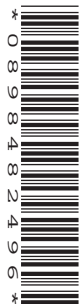

PHYSICS

0625/33

Paper 3 Theory (Core)

May/June 2023

1 hour 15 minutes

You must answer on the question paper.

No additional materials are needed.

INSTRUCTIONS

- Answer **all** questions.
- Use a black or dark blue pen. You may use an HB pencil for any diagrams or graphs.
- Write your name, centre number and candidate number in the boxes at the top of the page.
- Write your answer to each question in the space provided.
- Do **not** use an erasable pen or correction fluid.
- Do **not** write on any bar codes.
- You may use a calculator.
- You should show all your working and use appropriate units.
- Take the weight of 1.0 kg to be 9.8 N (acceleration of free fall = 9.8 m/s^2).

INFORMATION

- The total mark for this paper is 80.
- The number of marks for each question or part question is shown in brackets [].

This document has **16** pages. Any blank pages are indicated.

- 1 Fig. 1.1 shows the distance–time graph for an engineer’s journey. She drives from her home directly to her office and parks the car. She then drives from her office to her friend’s house and parks the car.

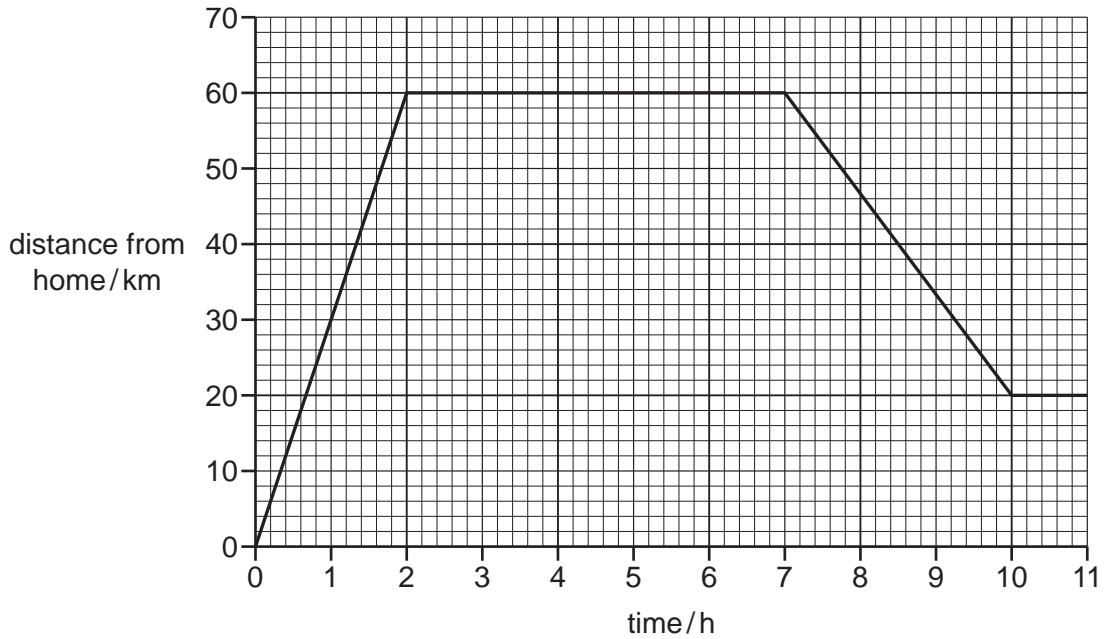

Fig. 1.1

- (a) Determine the distance between:
- (i) the engineer’s home and her office km [1]
 - (ii) the engineer’s office and her friend’s house. km [1]
- (b) Determine the time taken to travel between:
- (i) the engineer’s home and her office h [1]
 - (ii) the engineer’s office and her friend’s house. h [1]
- (c) Calculate the speed of the car between time = 7 h and time = 10 h.

speed = km/h [3]

[Total: 7]

2 Fig. 2.1 shows an engineer working with wind turbines.



Fig. 2.1

- (a) Complete the sentences describing how electrical power is generated by energy in the wind.
 - (i) The source of the wind energy is [1]
 - (ii) When the blades turn, electrical power is generated in the [1]
- (b) Describe **two** advantages, apart from cost, of generating electrical power by using wind turbines compared with using a coal-fired power station.

1

.....

2

.....

[2]

[Total: 4]

3 A student balances a beam on a pivot. They then balance block A and block B on the beam, as shown in Fig. 3.1.

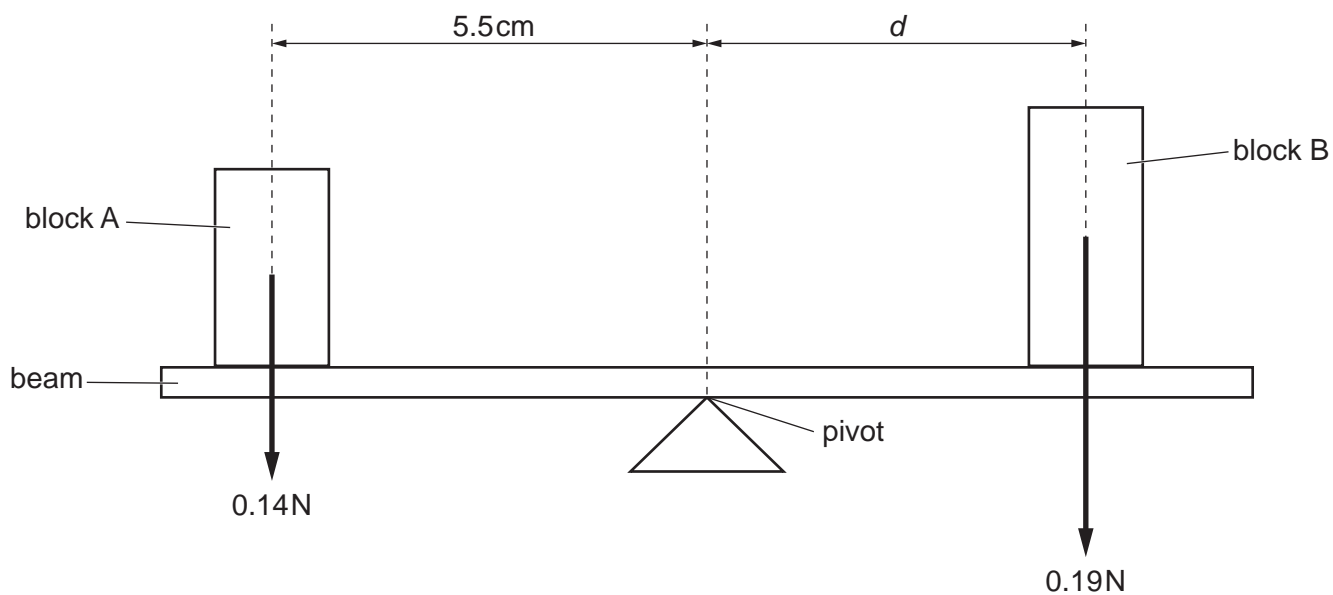

Fig. 3.1 (not to scale)

(a) (i) The weight of block A is 0.14 N.

Show that the moment of block A about the pivot is approximately 0.8 N cm.

[3]

(ii) The weight of block B is 0.19 N.

Calculate the distance d between the pivot and the centre of block B.

distance $d = \dots\dots\dots$ cm [3]

(b) The weight of block B is 0.19 N.

Calculate the mass of block B.

mass of block B = $\dots\dots\dots$ kg [3]

[Total: 9]

- 4 A tight-fitting lid keeps air inside a metal can. An airtight rubber bung holds a liquid-in-glass thermometer that is inserted through a hole in the lid, as shown in Fig. 4.1.

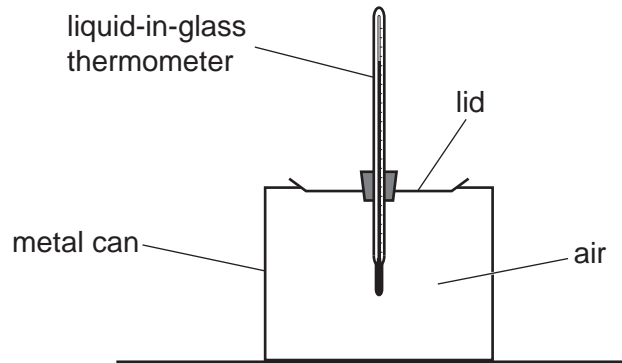

Fig. 4.1

- (a) (i) State what happens to the liquid in the thermometer when the air temperature rises.
 [1]

- (ii) The temperature of the air in the can is 18 °C.
 Calculate the temperature of the air in kelvin.

temperature = K [2]

- (b) The can is placed in a refrigerator. The temperature of the air inside the can decreases.
 State and explain what happens to the pressure exerted by the air in the can. Use your ideas about gas particles.

 [3]

- (c) The air in another can exerts a pressure of 102 000 N/m² on the lid. The area of the can lid is 0.0082 m².
 Calculate the force on the lid due to the air in the can.

force = N [3]

[Total: 9]

[Turn over

5 A teacher demonstrates the behaviour of waves by using water waves in a ripple tank.

Fig. 5.1 shows a cross-section through part of the water waves.

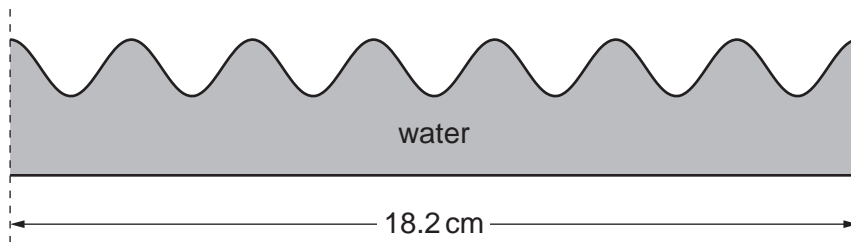

Fig. 5.1 (not to scale)

(a) Calculate the wavelength of the water waves. Use the information in Fig. 5.1.

wavelength = cm [2]

(b) The teacher places a pointer above the water waves as shown in Fig. 5.2.

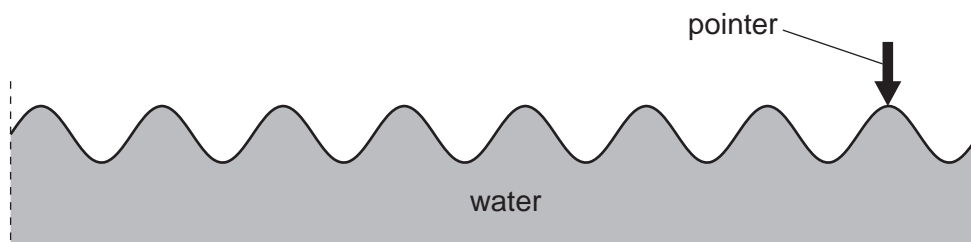

Fig. 5.2 (not to scale)

Three students use stop-watches to measure the time taken for 50 peaks to pass the pointer. Fig. 5.3 shows the measurements.



Fig. 5.3

(i) On the line below each stop-watch, state the time measurement, in seconds. [1]

(ii) Calculate the average of the three time measurements in (b)(i).

average time = s [2]

7

(iii) Calculate the frequency of the water waves using your result in (b)(ii).

frequency = Hz [2]

(c) The teacher repeats the demonstration using a different ripple tank and obtains these results for the waves.

wavelength = 0.025 m

frequency = 2.4 Hz

Calculate the speed of the wave.

speed of wave = m/s [3]

[Total: 10]

6 Table 6.1 shows regions of the electromagnetic (e.m.) spectrum.

Two of the regions are not labelled.

Table 6.1

| | | | | | | |
|------------|--------|-------|---------------|----------|-------|-------------|
| gamma rays | X-rays | | visible light | infrared | | radio waves |
|------------|--------|-------|---------------|----------|-------|-------------|

(a) (i) Complete Table 6.1 by writing the name of each region that is not labelled. [2]

(ii) State **two** properties that are the same for waves in all regions of the e.m. spectrum.

1

.....

2

.....

[2]

(b) X-rays are used in hospitals to check for broken bones.

(i) State **one** other use for X-rays.

..... [1]

(ii) State **one** precaution taken by people who work with X-rays.

..... [1]

[Total: 6]

- 7 (a) Students are investigating the refraction of light as it travels from air into glass.

Their task is to measure the angle of incidence and the angle of refraction at the surface of the glass block.

The students have the equipment shown in Fig. 7.1.

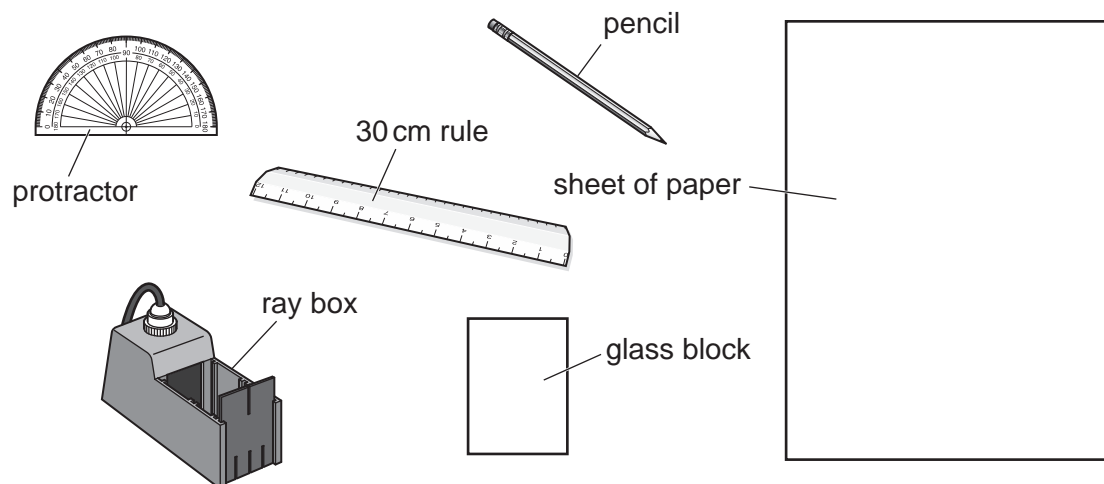

Fig. 7.1

Describe the method for the task.

You may draw a diagram as part of your answer.

.....

.....

.....

..... [4]

(b) Fig. 7.2 and Fig. 7.3 show two identical lenses, each forming an image. The images I_1 and I_2 have different characteristics.

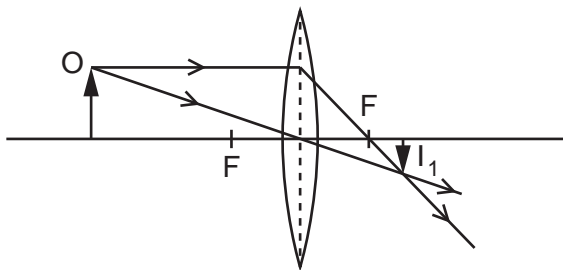

Fig. 7.2

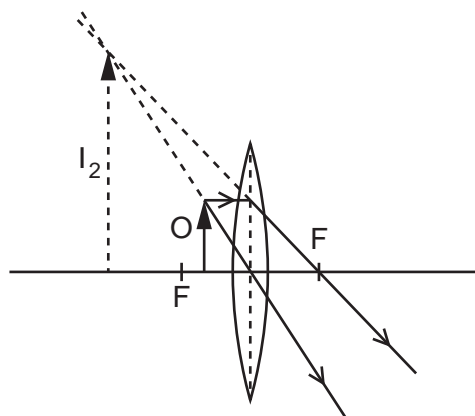

Fig. 7.3

One difference in the characteristics of the two images is:

Image I_1 is **diminished** but image I_2 is **enlarged**

State **two** more differences in the characteristics of the images:

Image I_1 is but image I_2 is

Image I_1 is but image I_2 is

[3]

[Total: 7]

8 (a) Fig. 8.1 shows the electrical symbols for some circuit components.

Draw a line from each electrical symbol to the name of the circuit component it represents.

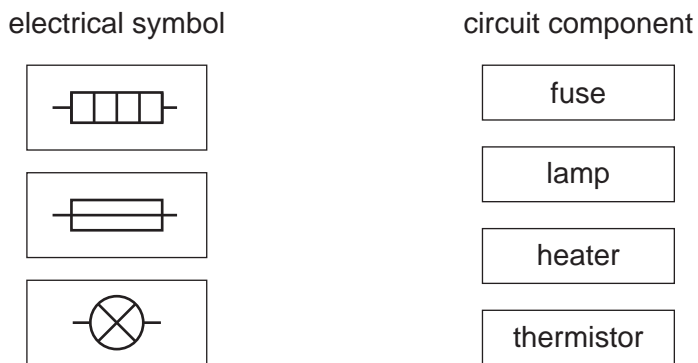

Fig. 8.1

[3]

(b) Fig. 8.2 shows a circuit including a battery, a fixed resistor R and an ammeter.

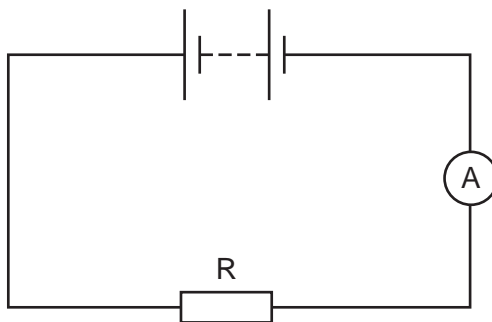

Fig. 8.2

The reading on the ammeter is 0.38A.

The potential difference across the fixed resistor R is 12V.

(i) Calculate the resistance of the fixed resistor R.

resistance = Ω [3]

(ii) Calculate the electrical power transferred in the fixed resistor R. Include the unit.

power transferred = unit [4]

[Total: 10]

- 9 Fig. 9.1 represents an atom of beryllium. The labels A, B and C indicate three types of particle.

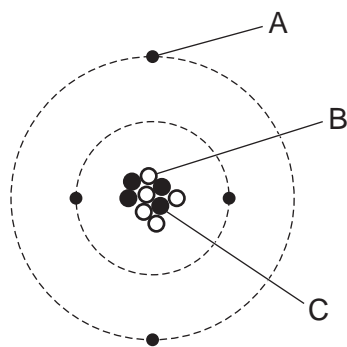

Fig. 9.1

- (a) (i) Complete Table 9.1.

Name each type of particle and state the sign of its charge.

One row is done for you.

Table 9.1

| type of particle | name | sign of charge |
|------------------|--------|----------------|
| A | | |
| B | | |
| C | proton | positive (+) |

[3]

- (ii) There are several different isotopes of beryllium.

State what is meant by the term isotope.

.....
 [2]

(b) Fig. 9.2 shows sources of background radiation that affect people.

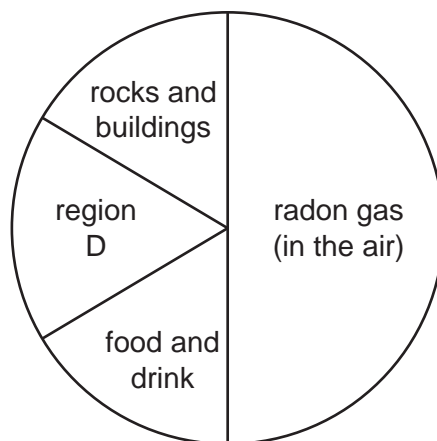
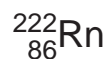

Fig. 9.2

Suggest the source of background radiation in region D.

..... [1]

(c) The nuclide notation for an atom of radon is:



(i) State the number of protons in this atom of radon. [1]

(ii) State the number of particles in the nucleus of this atom of radon. [1]

[Total: 8]

10 Fig. 10.1 represents part of the Solar System.

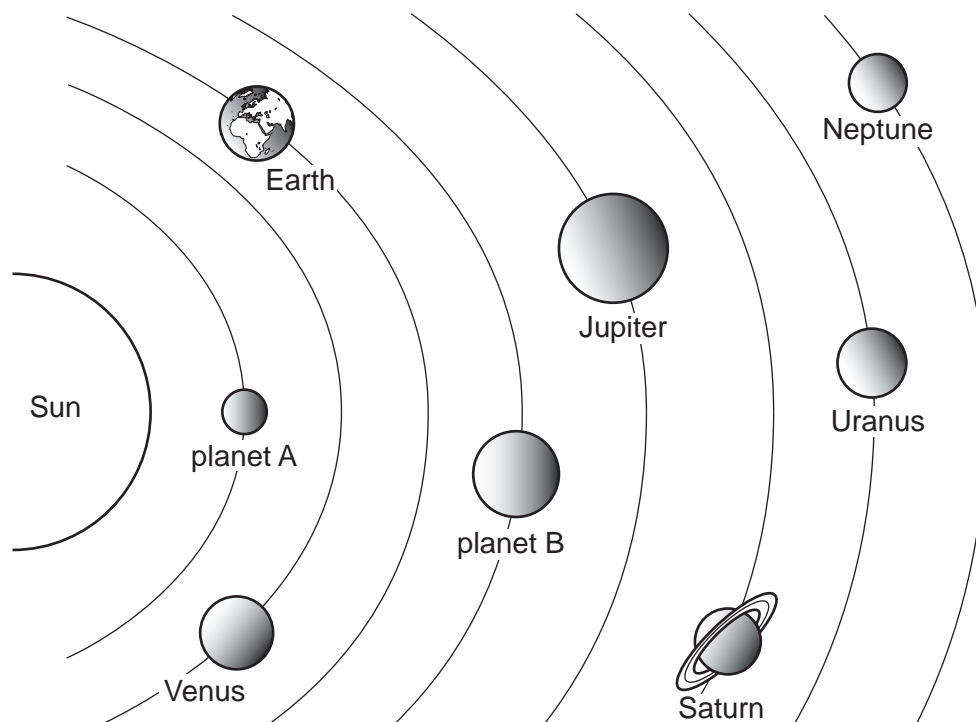

Fig. 10.1 (not to scale)

(a) (i) State the name of planet A and the name of planet B.

planet A

planet B

[2]

(ii) On Fig. 10.1, draw an X to represent a moon of Jupiter. Draw a line to show how this moon moves. [1]

(iii) State **two** ways in which the four planets nearest to the Sun are different from the four planets furthest away from the Sun.

1

2

[2]

(iv) Complete the following sentences:

The galaxy that includes the Solar System is called the

The includes billions of galaxies.

[2]

15

- (b) The distance between the Sun and the Earth is 1.5×10^{11} m.
The speed of an electromagnetic wave is 3.0×10^8 m/s.

Calculate the time taken for an electromagnetic wave to travel from the Sun to the Earth.

time taken = s [3]

[Total: 10]

BLANK PAGE

Permission to reproduce items where third-party owned material protected by copyright is included has been sought and cleared where possible. Every reasonable effort has been made by the publisher (UCLES) to trace copyright holders, but if any items requiring clearance have unwittingly been included, the publisher will be pleased to make amends at the earliest possible opportunity.

To avoid the issue of disclosure of answer-related information to candidates, all copyright acknowledgements are reproduced online in the Cambridge Assessment International Education Copyright Acknowledgements Booklet. This is produced for each series of examinations and is freely available to download at www.cambridgeinternational.org after the live examination series.

Cambridge Assessment International Education is part of Cambridge Assessment. Cambridge Assessment is the brand name of the University of Cambridge Local Examinations Syndicate (UCLES), which is a department of the University of Cambridge.